

ชุดยกประตุน้ำบานเลื่อน

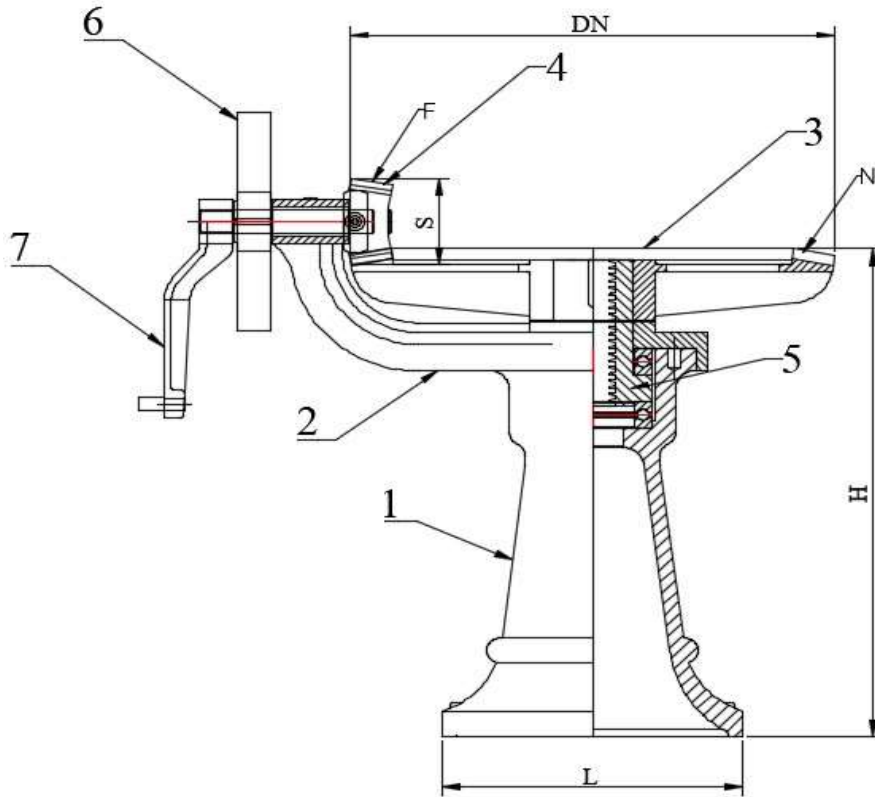

ตารางรายละเอียดเครื่องยก

เครื่องยกขนาด (กก.)	N (จำนวนฟัน)	F (จำนวนฟัน)	DN	S	L	H
3000	68	17	544	136	408	880
4000	68	17	544	136	460	916
6500	96	16	813	153	505	901

NO	PART NAME	MATERIAL	REFERENCE
1	Stand	Ductile Iron / Cast Iron	A 536 Grade 65 / A 126 Class B
2	Arm	Ductile Iron/Cast Iron	A 536 Grade 65 / A 126 Class B
3	Bevel Gear A	Ductile Iron/Cast Iron	A 536 Grade 65 / A 126 Class B
4	Bevel Gear B	Ductile Iron/Cast Iron	A 536 Grade 65 / A 126 Class B
5	Yolk Sleeve	Bronze	B 62
6	Spur Gear	Ductile Iron/Cast Iron	A 536 Grade 65 / A 126 Class B
7	Hand Wheel	Ductile Iron/Cast Iron	A 536 Grade 65 / A 126 Class B



CHAIPONG ENGINEERING CO.,LTD.

Tel : 02-482-1526-7 Fax : 02-019-8911

email : chaipong_cpe@hotmail.com

Line ID : @chaipong